

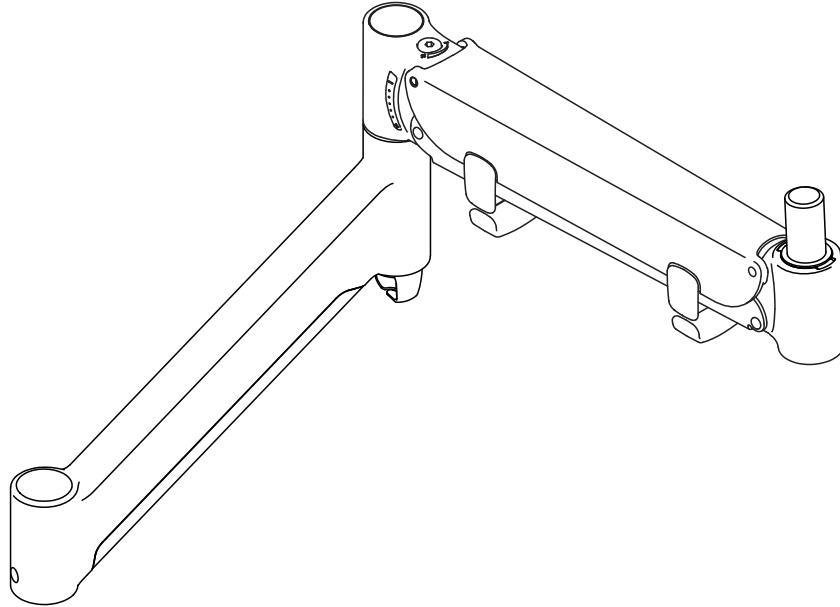

Heavy Duty Dynamic Arm

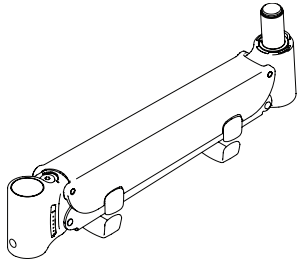
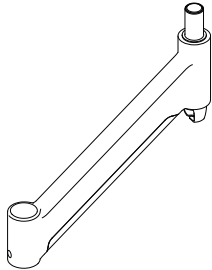

| COMPONENT CHECKLIST | | | REQUIRED TOOLS |
|--|--|--|--|
|  <p>A Heavy Duty Dynamic Link (x1)</p> | | | <p>All tools supplied</p> |
|  <p>B Lower Angled Link (x1)</p> | | | |
|  <p>C 4mm Allen Key (x1)</p> | | | <p>WEIGHT RANGE</p> <p>Desk Base Mount 6 - 16kg (13 - 35lb)</p> <p>Post Mount 6 - 14kg (13 - 31lb)</p> <p>Monitor weight should be within the weight range of all modular elements that make up the complete monitor mounting solution.</p> |

IMPORTANT INFORMATION

- ! Please ensure this product is installed as per these installation instructions.
- ! Curved monitors, deep devices (such as all-in-one PCs) and offset VESA locations exert additional leverage that can exceed the capacity of the mount even though the monitor weight may be within the stated range.
- ! The manufacturer accepts no responsibility for incorrect installation.
- ! This product is compatible with AWM Series monitor arm products.

1. Assemble Arm Links

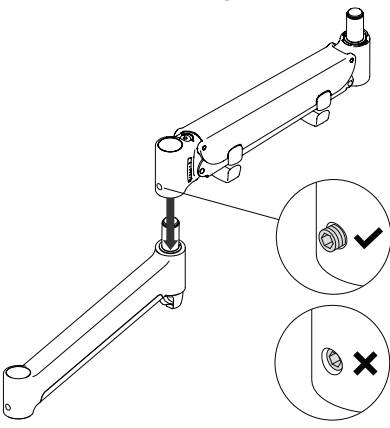
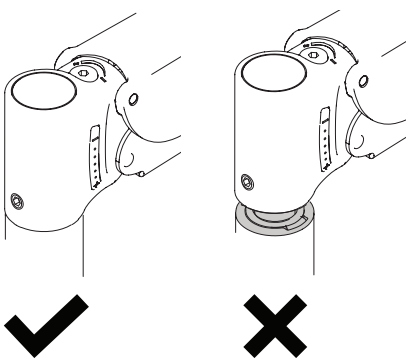
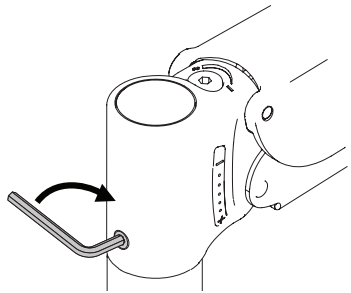
| | | |
|---|--|--|
| <p>1.1 Push two arm links together</p>  | <p>1.2 Ensure arm is fully pushed together</p>  | <p>1.3 Tighten set screw</p>  <p>Note: Check that arm rotation is smooth after tightening</p> |
|---|--|--|

2. Fit arm onto Arm Base (AWM-LB) or Channel Clamp (AWM-LC) (sold separately)

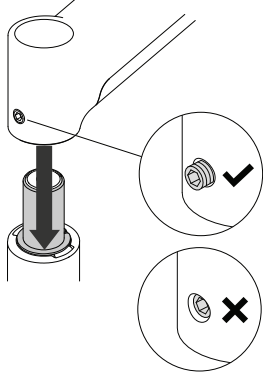
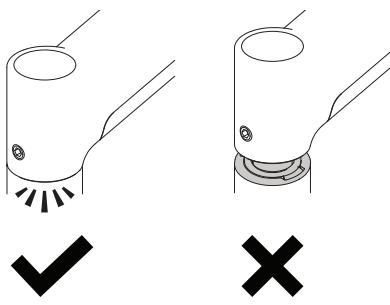
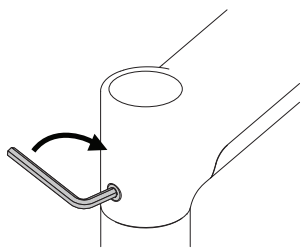
| | | |
|--|--|--|
| <p>2.1 Push arm onto shaft</p>  <p>Optional: Set joint rotation to 180° on Arm Base or Channel Clamp by following separate instruction manual.</p> | <p>2.2 Ensure arm is fully pushed onto base</p>  | <p>2.3 Tighten set screw</p>  <p>Note: Check that arm rotation is smooth after tightening</p> |
|--|--|--|

3. Fit Heavy Duty Tilt Head (AWM-LTH) or Dual Crossbar (AWM-LR) (sold separately)

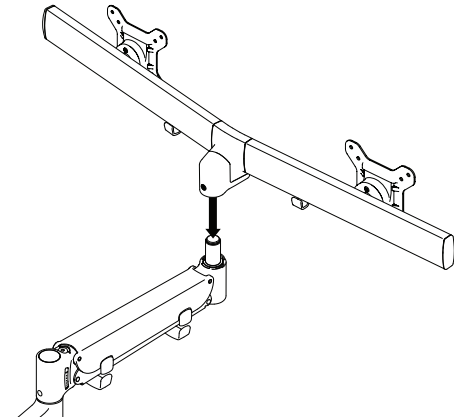
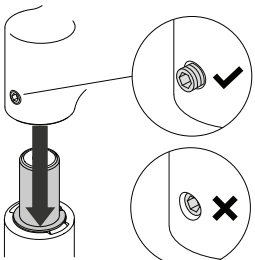
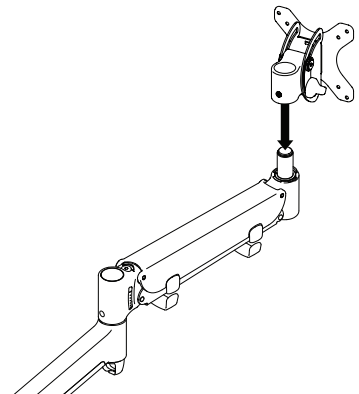
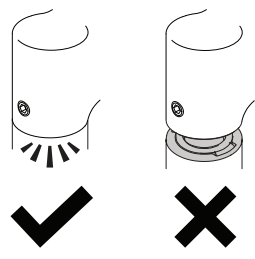
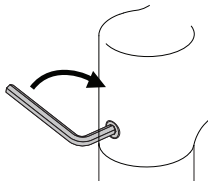
| | |
|--|--|
| <p>Dual Crossbar AWM-LR</p>  <p>To set up follow separate installation guide supplied with the Dual Crossbar</p> | <p>3.1 Push link onto shaft</p>  |
| <p>Heavy Duty VESA Tilt Head AWM-LTH</p>  <p>To set up follow separate installation guide supplied with the Heavy Duty Tilt Head</p> | <p>3.2 Ensure link is fully pushed onto shaft</p>  |
| <p>3.3 Tighten set screw</p>  <p>Note: Check rotation is smooth after tightening</p> | |

4. Adjust arm tension

4.1 Use the provided allen key to adjust the arm tension

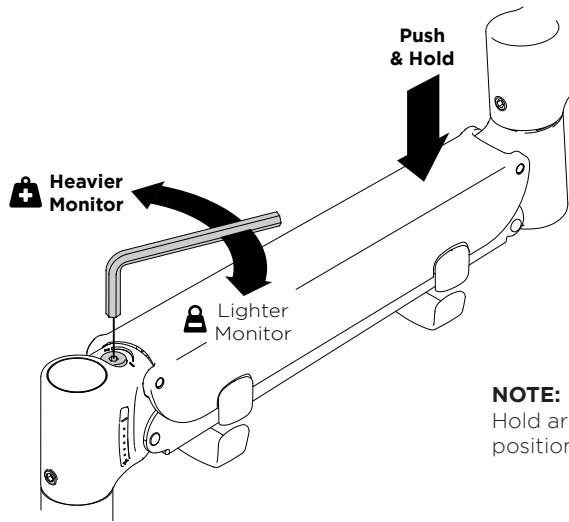

4.2 Installing multiple similar monitors?

1. Set up one monitor and record the position of the marker on the gauge.
2. When installing other similar monitors, pre-tension the arm to the recorded marker position then fine-tune the tension by following steps 4.3 to 4.5.

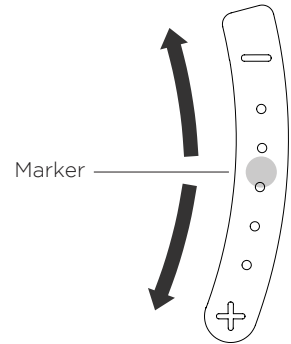

4.3 If the monitor sags or falls down, increase the arms tension by rotating the screw anti-clockwise.

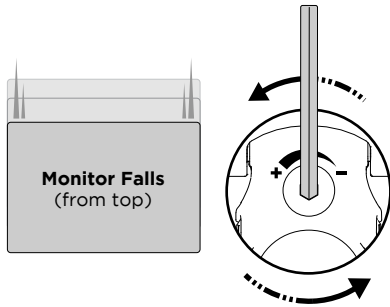

+ Increase Tension

4.4 If the monitor springs upwards, decrease the arms tension by rotating the screw clockwise.

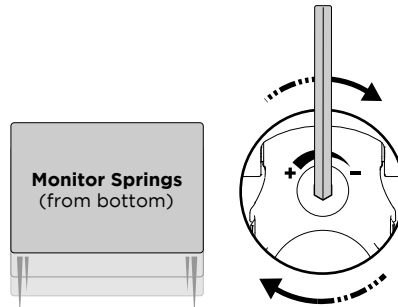

- Reduce Tension

4.5 If the monitor floats or hovers in all positions the arm tension is balanced and does not require further adjustment.

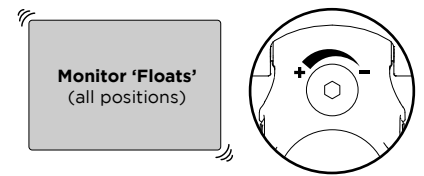

✓ Balanced

5. Cable management

5.1 Plug cables into the monitor and route the cables down the arm using the cable hooks and clips.

